

## 2E21 次世代技術経営 (MOT) の基盤を支える戦略ロードマッピング —Next-generation MOT and Integrated Strategic Roadmapping—

○亀岡秋男, 李 萌 (北陸先端科学技術大学院大),  
Steve Collins (北陸先端科学技術大学院大/University of Washington)

### Abstract

MOT (management of technology) led by government aims at improving the industrial competitiveness in Japan. With the rapid progress in science and technology, increasing diversity of society and globalization, existing management practices, especially those Japanese companies proud of during incremental innovation, may not be suitable enough for discrete innovation as well as sustaining competitive advantage. For generating new product concept, better forecasting future trends, new approach is needed. Thus, in this paper, roadmapping technique, which was developed in industry and has undergone shifts from simple forecasting to technology planning and to technology management, is introduced in Japan's MOT context as a strategic approach.

### 1. Introduction

Japan's economy is in the midst of an historic transition from a structure based on technological catch-up to one based on technological innovation at the frontier of knowledge. Whether it succeeds will depend on the country's capacity to generate and commercialize new knowledge across the economy. Though often criticized for its weakness in basic research and dependence on foreign know-how, Japan is actually well endowed with the scientific capabilities needed to generate new knowledge. Four Nobel Prizes in science and technology in the past three years should dispel any doubts about the country's capacity to contribute to the advance of knowledge. Moreover, Japan maintains a strong second place to the US in the generation of significant technological innovations as measured in patent statistics [1]. Finally, private and public sector spending on research and development continues to increase as both sectors recognize the growing contribution of science in technological innovation.

### 2. MOT Education in Japan

The MOT education systems in Japan are classified into the following three categories.

- Intra-company education.
- Open business seminars.
- University education.

Japanese industries have enjoyed high performance productivity in the high growth decades from the 1950s to the 1980s through the incremental innovations

achieved by improving the quality and reducing the cost within a given dominant product concept. These activities require teamwork and interactive collaboration among individuals as well as organizations; management requires long experience and the sticky, tacit knowledge of the relevant fields. In manufacturing management, Japan has succeeded in establishing powerful methodologies such as QC, TQC, and JIT and others. This may be interpreted as one of the reasons why MOT education in Japan has been carried out mostly inside the company.

The intra-company education systems have played so far an important role in the incremental innovation process. However, in-house training and education alone is no longer sufficient. Japanese industries are now expected to lead the global economy as a driving force. In such a rapidly advancing global and information-oriented economy, MOT requires much more sophisticated knowledge-based management equipped with higher speed and wider scope.

The open business seminars provide the success stories and practices of private companies, but their management experiences and knowledge are not integrated. The MOT education in Japanese universities is not well organized, nor do universities yet provide complete MOT programs consisting of a systematic curriculum. Accordingly, the Japanese MOT education system should be reformed as soon as possible, so as to provide systematically integrated knowledge, which is a mission of universities and open non-profit organizations.

Currently in Japan, the small supply of MOT experts cannot keep pace with demand. In 2003, only around 540 persons acquired MOT degrees in Japan—360 through universities and 180 through private educational institutes. In contrast, about 10,000 students annually receive comparable degrees in the US. In proportion to GDP, Japan would need to produce about 5,000 MOT professionals each year to be on par with the US. The US found itself in a similar position in the 1980s. In 1980, the US had only around 50 MOT programs in higher education institutions. After various reports such as the Young Report and the MIT report "Made in America" drew attention to the country's competitive problems, the number of such programs rose

dramatically, reaching 159 in 1994. Japan must do the same if it is to revitalize its economy.

### Government Policy for MOT

The Japanese government has begun to promote the development of educational programs and curricula that will boost the number professionals with expertise in MOT. These are part of a broader policy of fostering closer university-industry relations and encouraging technology transfer from university to industry. Major goals include the establishment of 1,000 university-based start-up companies within three years and an increase in the annual production of MOT professionals to 10,000, roughly equivalent to the annual total in the US, by 2007. Of special interest is the creation of MOT programs that prepare technologists for starting up and managing R&D-oriented venture businesses and managing innovation in biotechnology, information technology, environmental technology, and new materials. The objective is not merely to emulate MOT training in the US but to develop programs uniquely suited to the business environment and needs of Japanese firms.

With these goals in mind, METI is actively promoting the development and expansion of MOT programs that serve both university students and working technology professionals. In FY 2002, 120 million yen was budgeted for the Project for Promotion of Introduction of Human Resource Development Programs, in addition to a 2.9 billion yen supplemental appropriation; the budget for this fiscal year is 200 million yen. In this program, universities and industry will collaborate in a consortium to establish professional schools for management of technology that is expected to work as a driving force to train persons specializing in practical management of technology. This consortium is expected to work free from the existing university system. It will collaborate with private companies and business groups to identify industry needs, ensure those needs are reflected in programs, provide case examples of actual business activities, and ensure that personnel from business participate in managing technology programs. The major role of the consortium will be development of a shared text for technology managers and support staff of new start-ups, accreditation and skill standards, and systems for management of intellectual property. Projected participants include 63 companies from a wide range of industries and 38 public and private educational institutions.

In addition to the consortium, MOT curricula are being developed at 42 institutions throughout the country. Partnerships with private companies and foreign universities are also being encouraged.

Table 1. Development Examples of MOT Programs

Operation Management	Theory and implementation of operation, production, and supply.
Technology Process Management	Technology acquisition and strategic tie-up (including M&A); Innovation process; Knowledge management; Strategic utilization of intellectual property rights; Project management; Cross-companies and cross-organization technology transfer.
Technology marketing	Marketing for achievement of innovation and global technology marketing
Finance and accounting for management of technology	Finance and accounting.
Organizational theory for management of technology	Leadership theory for management of technology; Motivation management of engineering personnel and praxiology (including behavioral science); Decision making theory.
Theory and compendium on strategies for management of technology	Strategies for establishing new businesses by leveraging technology development projects (including concepts and designing); Technology forecast and technology assessment (including framework, core competence, focusing and statistics); Establishment of international strategies based on MOT (including ethics regarding technology development, negotiation and communication.

Examples of subjects being emphasized in model curricula include operations management, technology process management, technology marketing, finance and accounting for management of technology, organizational theory for management of technology, and theory and compendium on strategies for management of technology (Table 1).

### 3. Strategic Roadmapping

Roadmapping serves as an approach to linking real-world market with technology development with an industry or firm. For better understanding of roadmapping technique, we have to know what is the nature and purpose of a roadmap, and what it means to different organizations and how it is applied by stakeholders sometimes with diverse interests, as the nature, appreciation and usage determine the value of roadmap.

#### Roadmap

In general, roadmap reflects a common view of a group of representatives from different sectors in a particular field for a desired objective [5]. Robert

Galvin, former CEO of Motorola,<sup>1</sup> wrote in his often-quoted article:

A "roadmap" is an extended look at the future of a chosen field of inquiry composed from the collective knowledge and imagination of the brightest drivers of change in that field ... the inventory of possibilities for a particular field [2].

For industries concerned much with emerging technologies and dynamic markets, a good roadmap links front-end technology with business strategy. In relatively mature businesses, roadmaps, such as supply chain roadmap or value chain roadmap [12], often visualize the main gaps of technology, process, or organizational capability along chains, and help relevant functions or organizations timely align resources and prepare for needed capabilities. Figure 1 exhibits a classic roadmap designed by Motorola.

**Figure 1 Technology Roadmap Matrix**

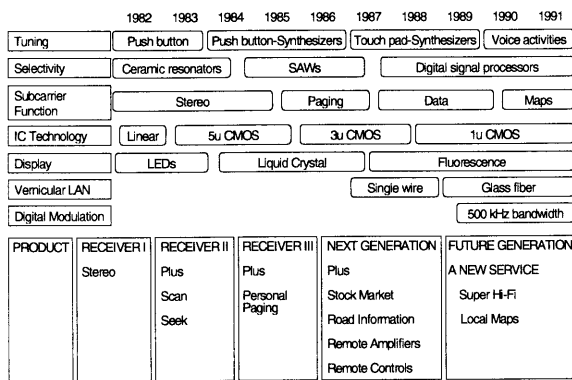

Source: [4]

It is difficult to make generalizations concerning the applications of roadmaps. Roadmaps range from new discovery in science to operational level of engineering, with time frame spans from a maximum of twenty years to monthly checkup. Some users find its use in benchmarking or monitoring competitors' activities; others may fully employ it as major vehicle of strategic planning. Diverse treatments of roadmaps by different users give a mixed picture.

### Roadmapping

Roadmapping is a process in which a roadmap is discussed, charted, and periodically revised by groups of roadmappers - people from different functions or

organizations for potential future objectives. On the one hand, complexity of R&D, product designs, and production processes themselves is rapidly growing; on the other hand, competition and changing customer's preferences stirred by variety of innovations aggravate the complexity, which places traditional technology forecasting and planning into a dilemma [14-15]. Obviously, the roadmapping process determines the quality of roadmaps, effective application of roadmaps as well as the attractiveness of roadmaps and roadmapping technique.

Roadmapping, a collective learning process, emerges to meet the needs of lowering risks caused by uncertainty and complexity from industries: integrating technology development and business decision making, access to external resources via networks, creating a new platform and linking tools to coordinate consistent activities among partners. In the roadmapping process, people involved share information and exchange views on future technologies, prospects, etc. General agreement and commitment are reached through interactive influence, negotiation or coercion [4].

**Figure 2 Generic Technology Roadmapping**

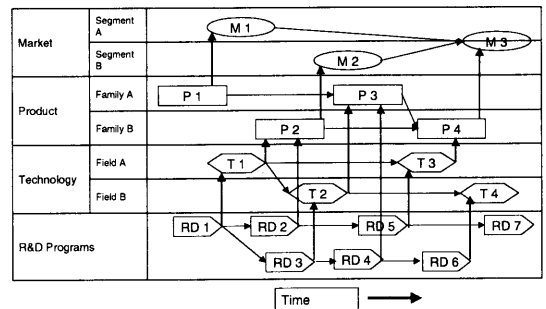

Based on the center of attention of roadmapping in practice, Kappel, classified general roadmapping processes into four large categories [3]:

- Roadmapping as forecasting process
- Roadmapping as planning process
- Roadmapping as decision-making process
- Roadmapping as design process

Another author suggested that roadmapping be an agent of change [8]. And more recently, roadmapping is considered as an integrated management tool. For example, technology roadmapping was considered as an integrated technology management linking technology and business [6][9] (See Figure 2 and Table 2).

<sup>1</sup> It is widely believed that Motorola is the original creator and user of roadmap in its planning processes.

Table 2 Scheme of technology roadmapping

1	Pre-project phase	
2	Setting up the team	
3	Preliminary plan for the technology roadmapping project	
4	Processing of the inputs	↩
5	Compression to a working document (technology roadmap)	↩
6	Checking, consulting, communication planning	↩
7	Formulation of a decision document (optional)	↩
8	Update	

Source: [13]

Whether roadmapping aims at the frontiers of science and technology, or product technology, supply chain, or integrates the entire value chain, roadmappers have to face the same objective: achieve a general consensus on major objectives (even tentatively) by sharing information and making a compromise on actions. They also use roadmaps as a focus of attentions to prioritize their strategic tasks [3].

#### Roadmapping as Technology Management

Given the growing importance of roadmapping in creating new knowledge in identifying emerging fields, aligning internal and external resources, and integrating emerging technologies with business concepts, we should consider it as part of knowledge management.

Roadmapping is not a once-for-all approach. The frequency of roadmapping depends on specific demand and the nature of the roadmap. However, ahead of each gate or the beginnings of the four phases (emergence, selection, planning, and action), roadmapping activities offer a unique arena and opportunities bringing a variety of specialists with varied experiences to the same table for sharing mental models, experiences and generating new knowledge. It is the conceptual and systemic knowledge generated that then triggers the dynamics of knowledge activities in each phase. Newly crystallized knowledge would justify the roadmapping and may significantly improve the quality of roadmaps and accountability of owners.

#### 4. Conclusion

Improving the competitiveness of Japanese industries asks for new practices and education system like MOT. However, the new methodologies and approaches are needed for tackling the new issues. So we suggest adding roadmapping curriculum in new MOT program as a powerful integrated approach to organically link many components together.

To establish new-type knowledge-creation and build capabilities in companies go with roadmapping, which makes the roadmapping technique more valuable and attractive not only for strategic planning but integration of whole process along value chain. Moreover, roadmapping processes ought to create added value in terms of knowledge management rather than simply communicate messages, while gaining anticipations and commitments of participants to potential actions. The related crucial questions are how to mobilize personal knowledge - intangible, tacit dimension of knowledge - owned by individuals, how to foster friendly atmospheres and make creative tensions allowing graceful flows of knowledge in and across groups, sectors, functions and organizations in roadmapping processes.

#### Reference

- [1] "In Search of the World's Hotbeds of Innovation," *Financial Times* (19 May 2003), p. 10.
- [2] Galvin, R. "Science Roadmaps," *Science*, vol. 280: 803, May 8, 1998.
- [3] Kappel, T. A., *Technology Roadmapping: a Evaluation*, Ph. D Dissertation, Northwestern University, 1998
- [4] Probert, D., and M. Radnor, "Frontier Experiences From Industry-Academia Consortia," *Research-Technology Management*, March—April: 27-30, 2003.
- [5] Willyard, C. H., and C. W. McClees. "Motorola's Technology Roadmap Process," *Research Management*, 30 (5): 13-19, 1987.
- [6] Groenveld, P. "Roadmapping Integrates Business and Technology," *Research-Technology Management*, 48-55, 1997.
- [7] Phaal, R., and C. Farrukh, and D Probert. *T-Plan: The Fast Start to Technology Roadmapping*, University of Cambridge, UK, 2001.
- [8] McMillan, A., "Roadmapping - Agent of Change," *Research-Technology Management*, March-April: 40-47, 2003.
- [9] Bucher, P., *Integrated Technology Roadmapping: Design and Implementation for Technology-based Multinational Enterprises*, Ph.D Dissertation, Swiss Federal Institute of Technology Zurich, 2003.
- [10] Nonaka, I. "The Knowledge creating Company," *Harvard Business Review*, Nov.-Dec.: 96-104, 1991.
- [11] Nonaka, I., "A Dynamic Theory of Organizational Knowledge Creation," *Organization Science*, 5: 14-37, 1994.
- [12] Fine, C. H., *Clockspeed*, Addison- Wesley, San Francisco, CA 1998.
- [13] EIRMA, *Technology Roadmapping: Delivering Business Vision*, Working Report, No. 52, Paris, 1997.
- [14] Beinhocker, E. D., and S. Kaplan, "Tired of Strategic Planning?" *McKinsey Quarterly*, 2002.
- [15] Mintzberg, H. *The Rise and Fall of Strategic Planning*, New York, NY: Free Press, 1994.
- [16] Christensen, C. M., *The Innovator's Dilemma*, Boston, MA: Harvard Business School Press, 1997.