



LORT: A Web 2.0 federated repository of e- Learning content in Taiwan

Chen-Yu Lee, PhD (李鎮宇)

leoli@iii.org.tw

Digital Education Institute

Institute for Information Industry (III),

Taiwan, R.O.C.



Outline

- What is LORT
- A Web 2.0 federated repository
- Demonstration



Digital Education Institute (DEI), Institute for Information Industry (III)



<http://www.iii.org.tw>

Institute for Information Industry (III)

- Established in 1979 as a non-governmental organization
- Jointly sponsored by the Taiwan government and prominent private enterprises

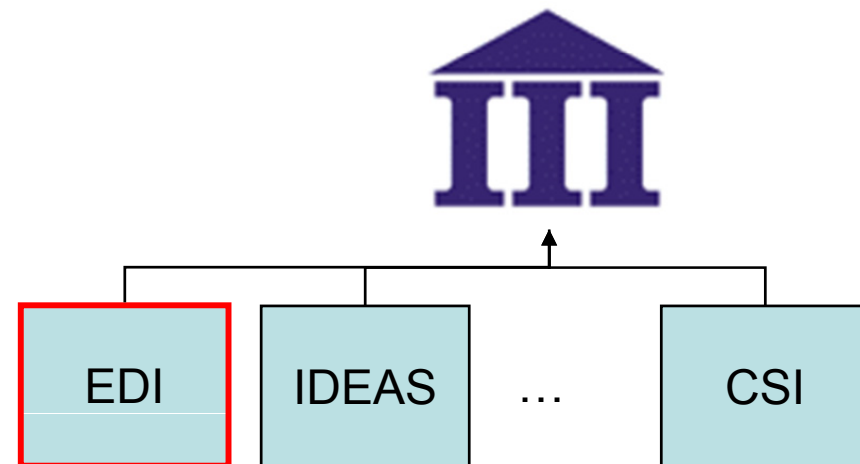



Digital Education Institute

ICCE 2007

- e-Learning think tank for the Taiwan government.
- Leverage the government, the industry, the academy and the R&D organizations to develop Taiwan e-Learning industry.
- Promote effective e-learning to **enhance industrial competitiveness.**

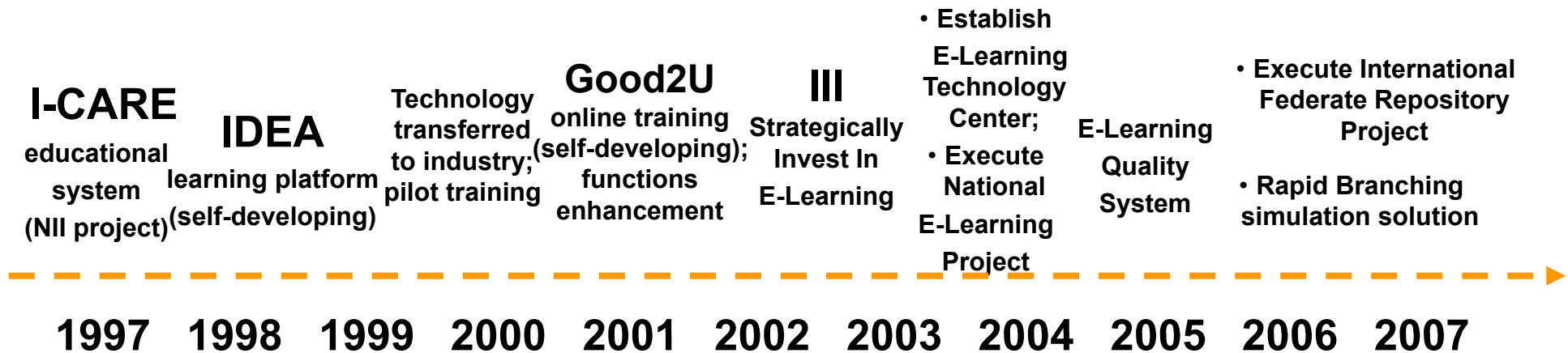



LORT: Learning Object Repository in Taiwan



From e-Taiwan to UNS of Taiwan

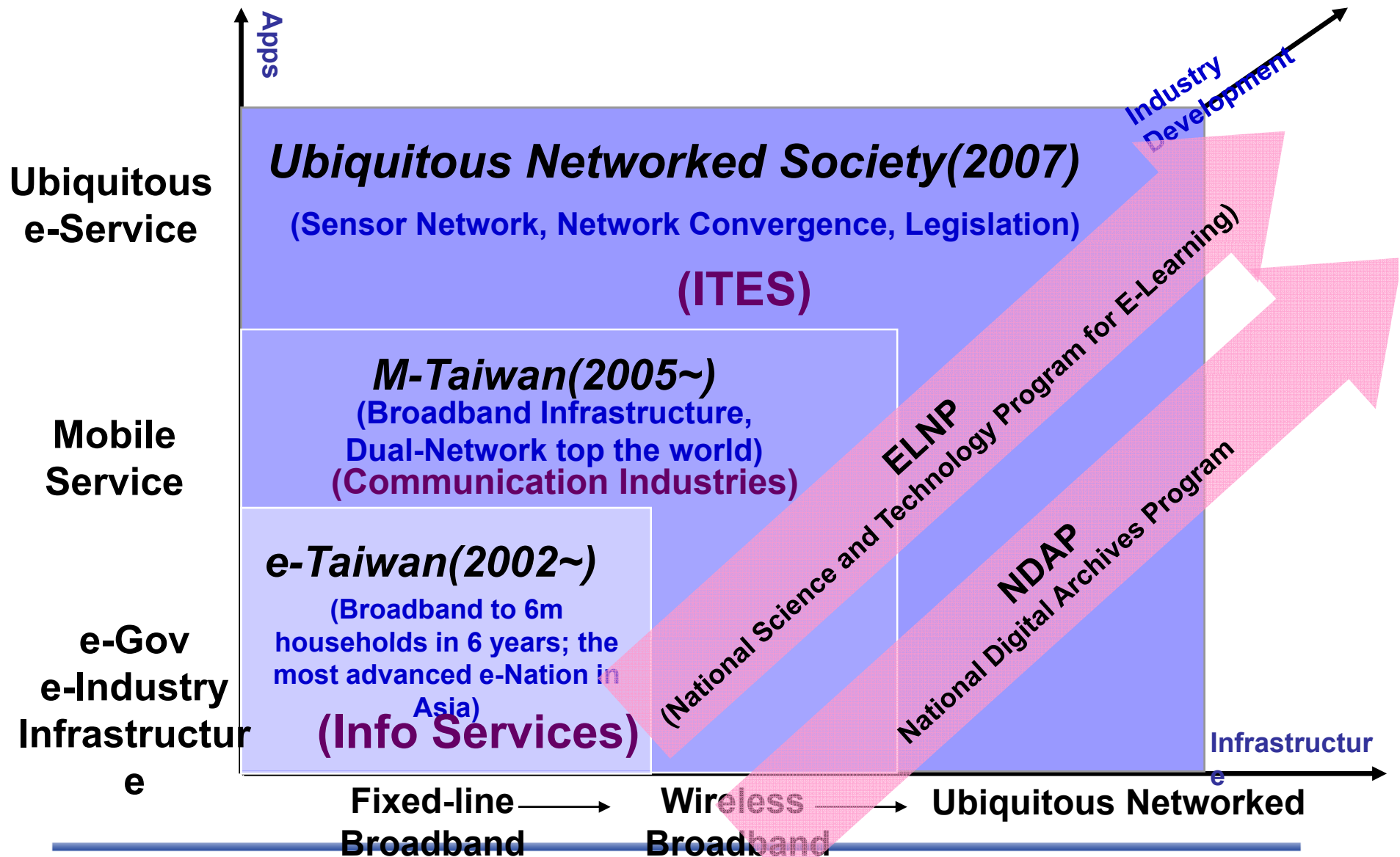



A Learning Portal for Taiwan

National e-Learning Program
National Digital Archives Program

LORT:
Learning Object Repository in Taiwan

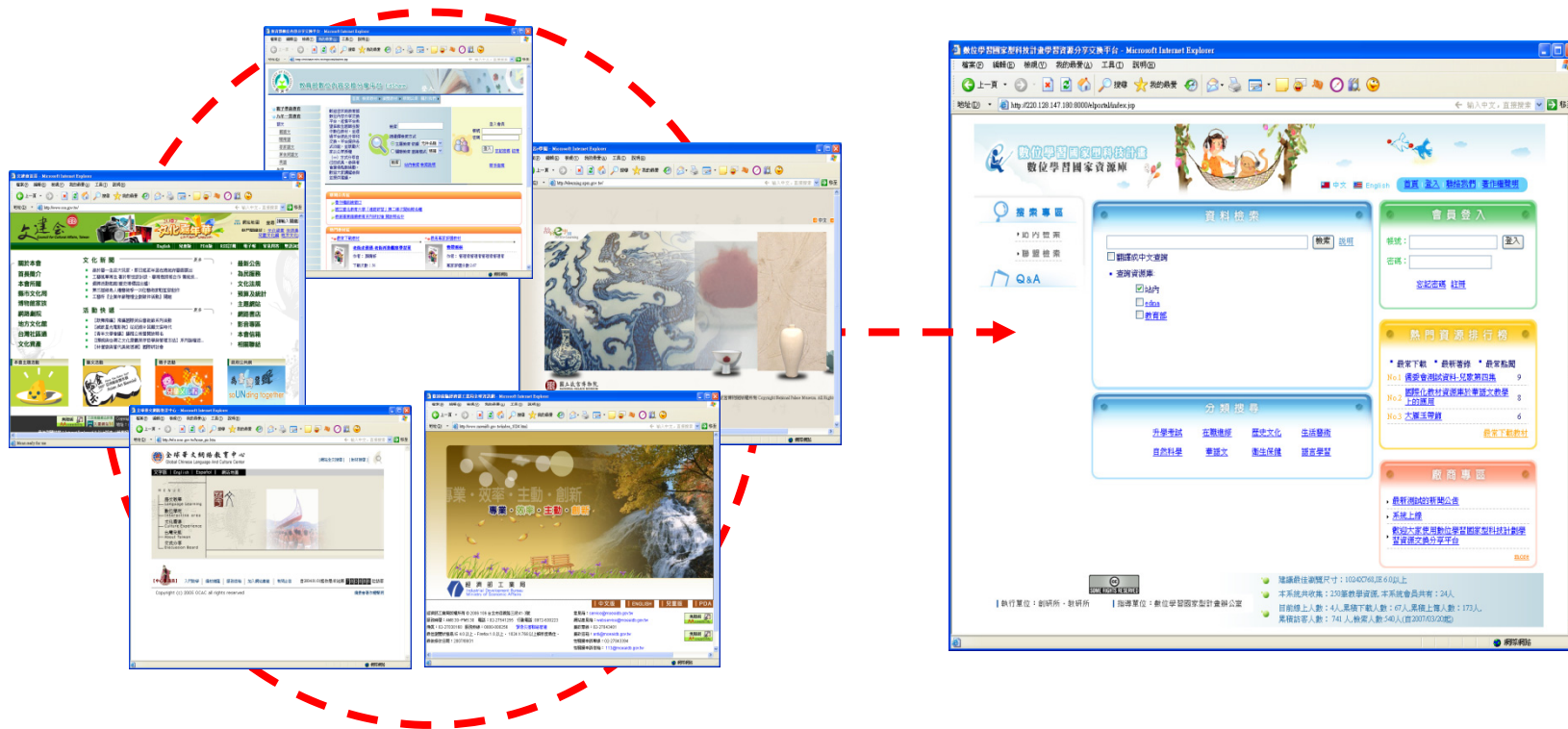



The LORT network

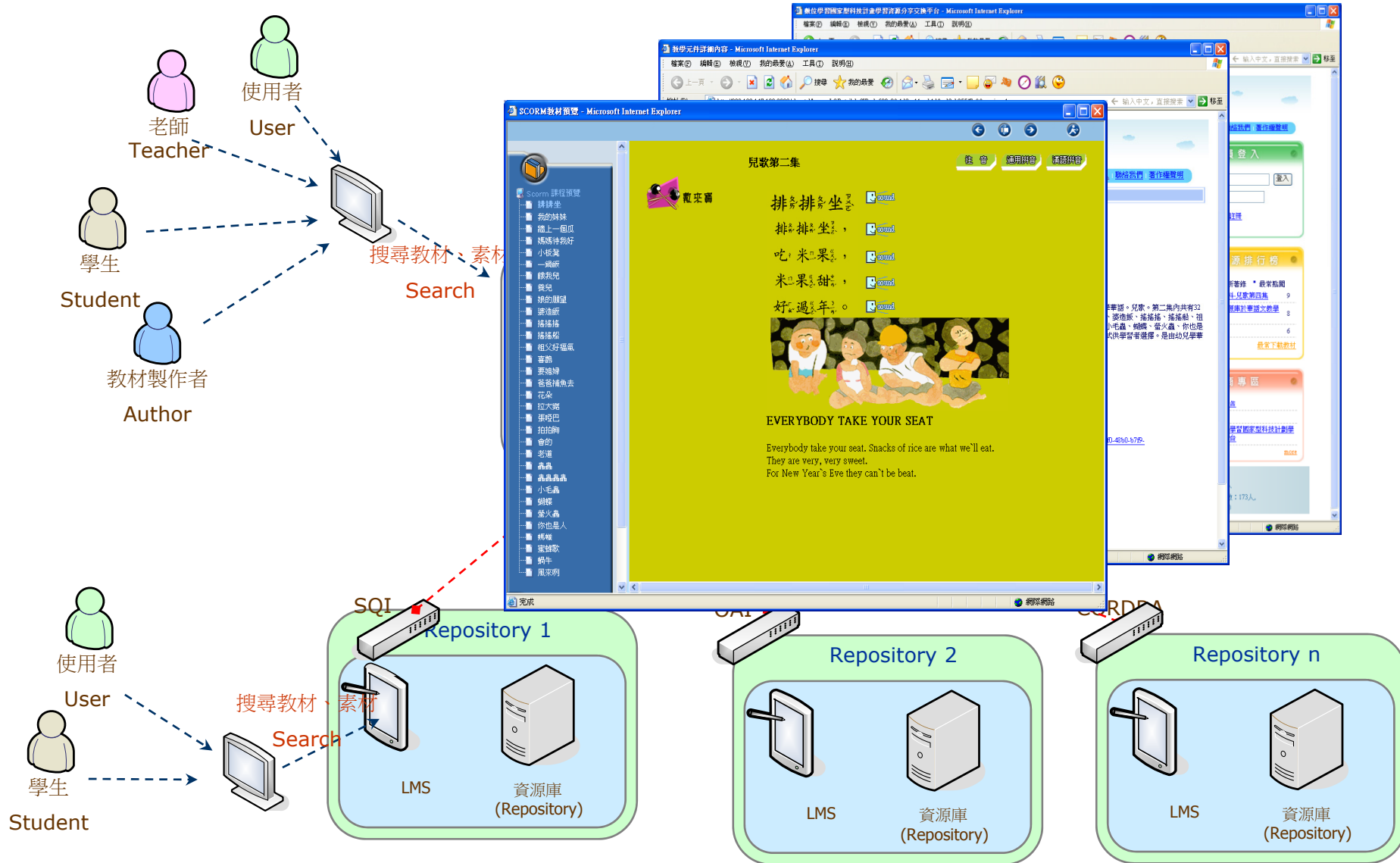



Vision of LORT

Chinese Language Learning business

- The Largest Chinese Learning repository in the world
- To support learning industry of selected e-Learning domain (Chinese language) in the world

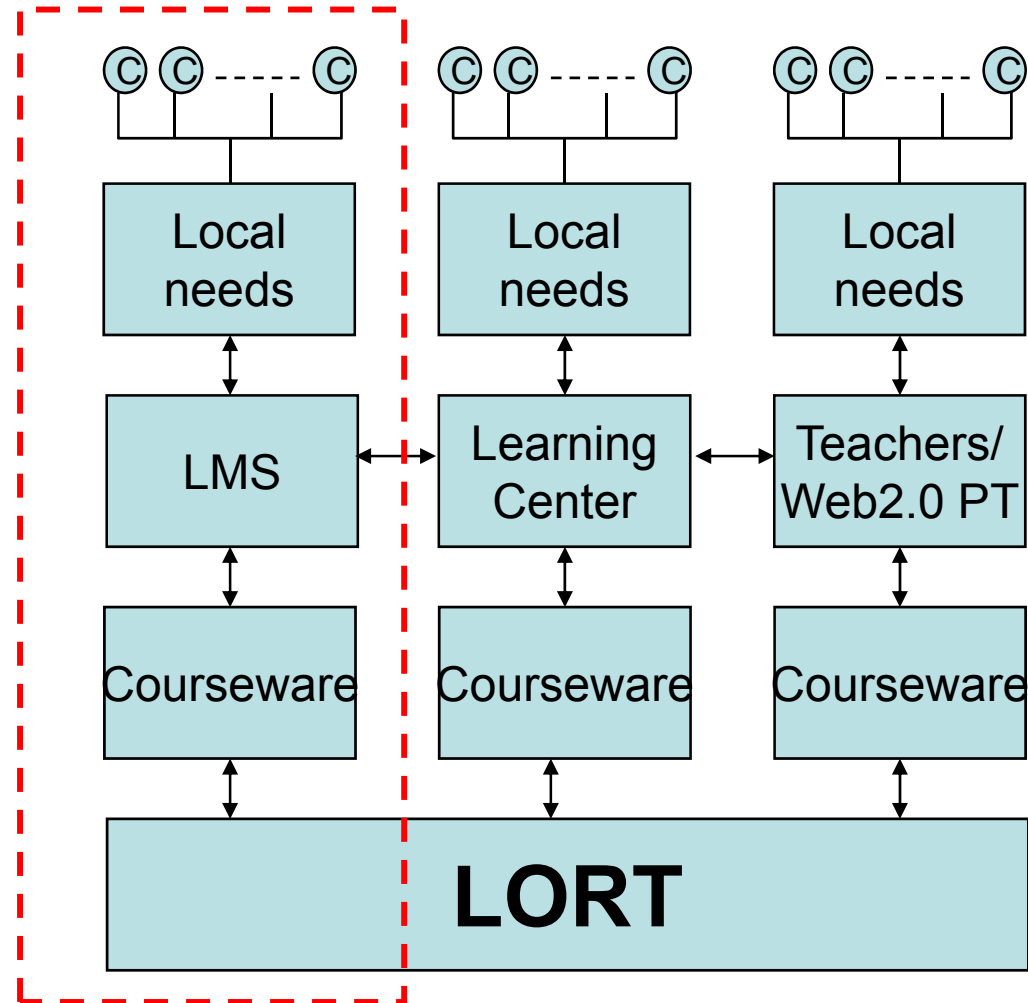

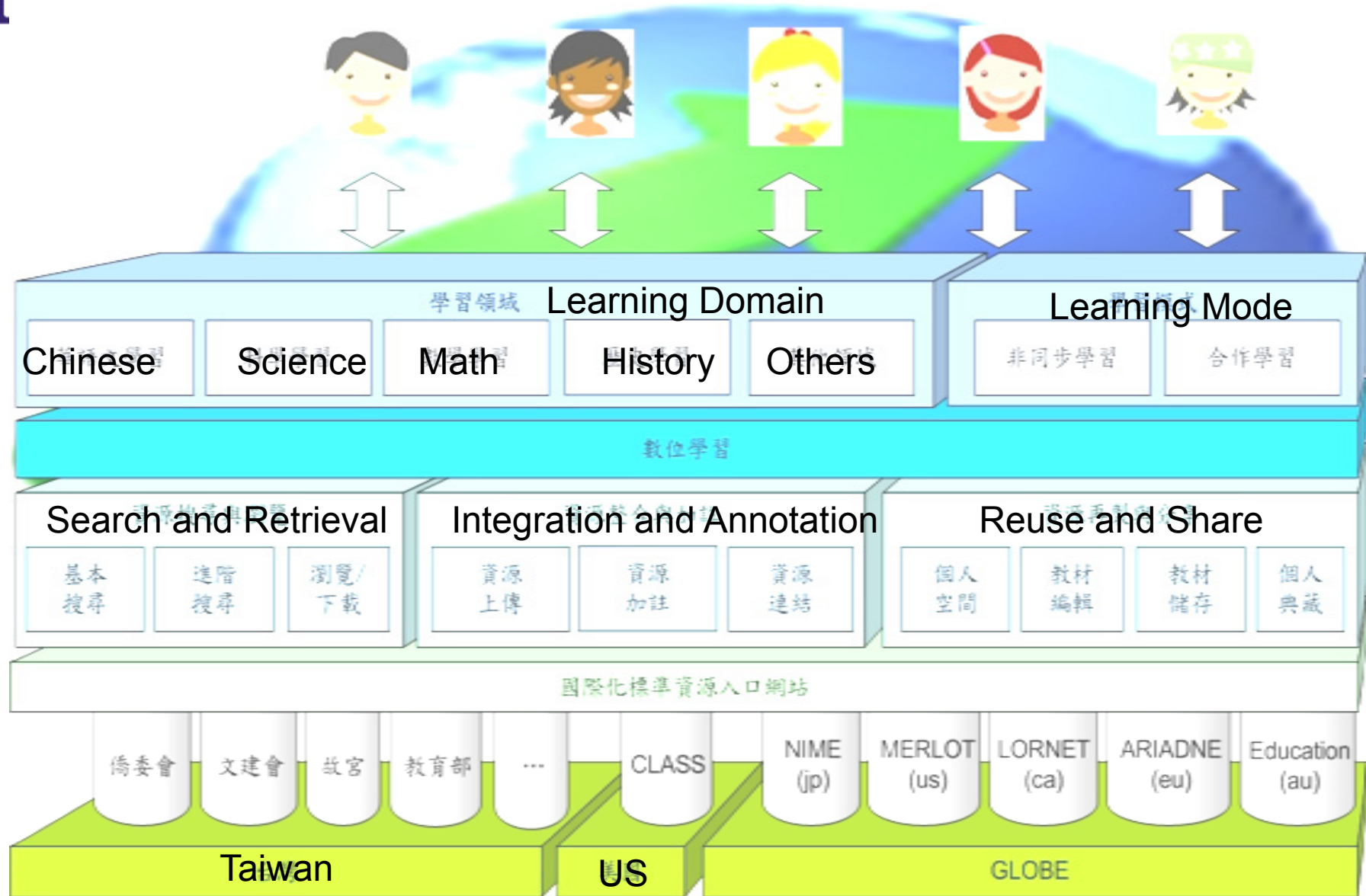



Progress



13 Partners

LORT

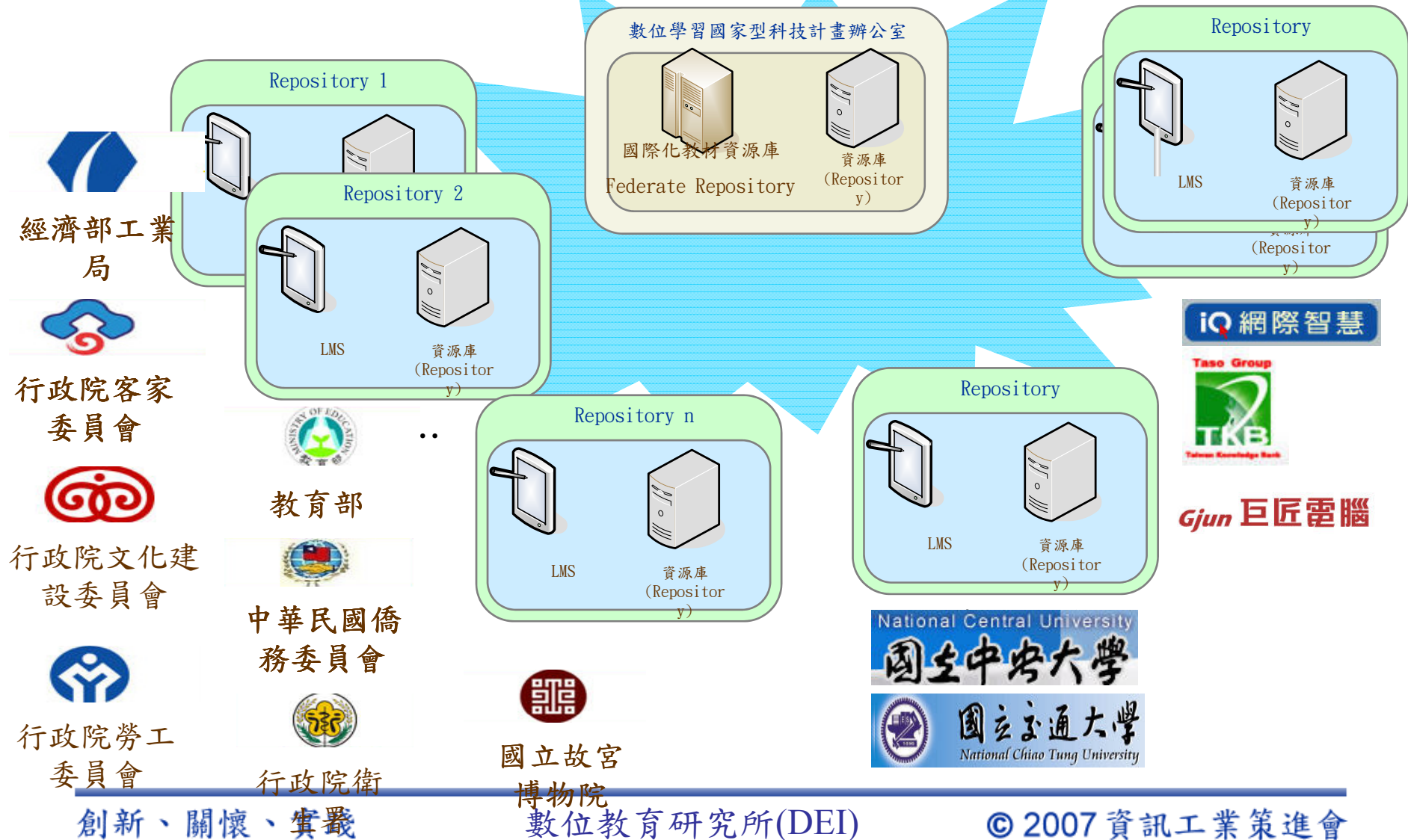



The LORT network

數位學習國家資源庫
LORT

Repository 1

LMS 資源庫 (Repository)

教育部

Repository 2

LMS 資源庫 (Repository)

行政院文化建設委員會

數位學習國家型科技計畫辦公室

國際化教材資源庫
Federate Repository

資源庫 (Repository)

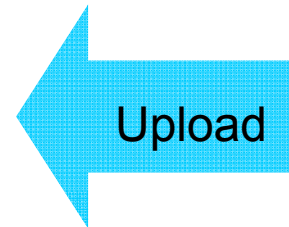

Repository n

LMS 資源庫 (Repository)



經濟部工業局



中華民國僑務委員會



Gjun 巨匠電腦









國立交通大學
National Chiao Tung University

National Central University
國立中央大學





Government agencies

Agency department	Learning Content	Learning Asset (material)
 經濟部工業	19	0
 勞工委員會	264	0
 僑務委員會	100+	8800
 客家委員會	100+	0
 教育部	100+	5065
 故宮	6	0
total	589+	13865





Industry Vendors

vendor	Learning Content	Learning Asset
	7	0
	5	0
	13	0
Total	35	0



Universities

University	Learning Content	Learning Asset
 國立交通大學 <i>National Chiao Tung University</i>	19	0
National Central University  國立中央大學	37	0
Total	56	0



More Learning resources will join

Current # Learning objects in LORT	680+	13,865
Department of Taiwan culture affair	300	0
National Digital Archives Program	0	1,433,927
National Palace Museum	0	20,000+
Ministry of Economic Affairs - Small and Medium Enterprise Administration	541	0
Other government agency	1500+	5000+



- First announcement
 - 2007/06/13
- Official announcement
 - 2007/10/ 25
- Dr. Lin
 - Director of Digital Education Institute ,III





A web 2.0 concept

Everyone contribute contents



System architecture

Retrieve Learning resources + Personal configuration + Other (official) repository

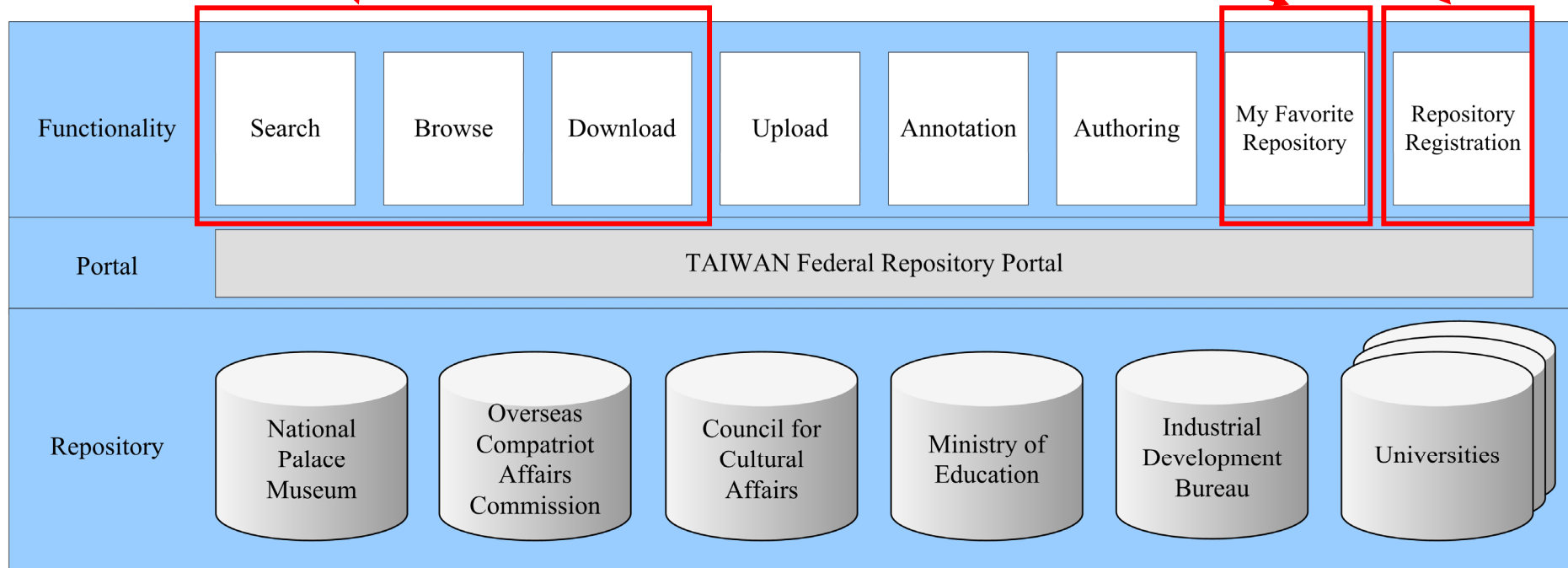



Retrieval in 4 steps

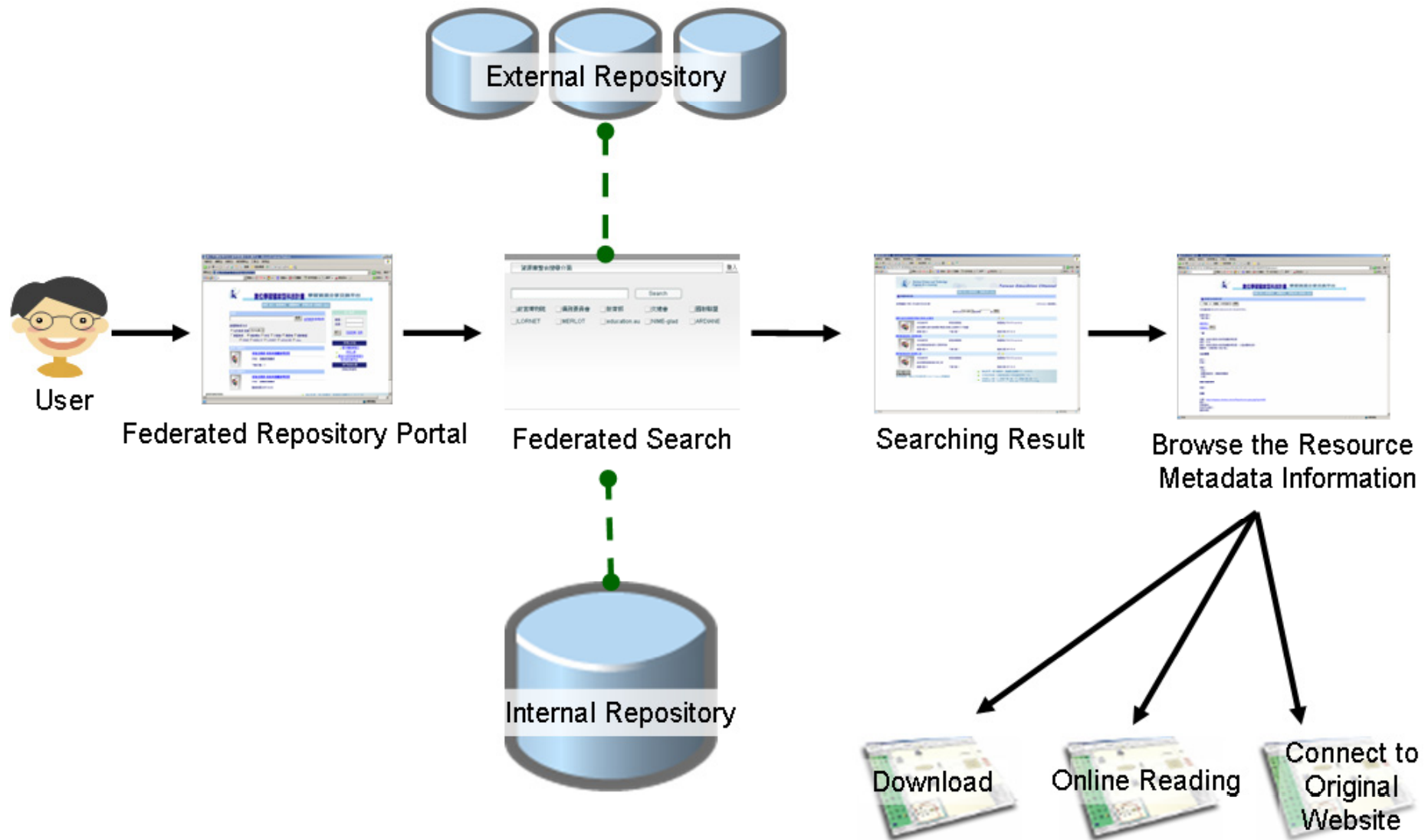

Teaching (Using) will be earlier

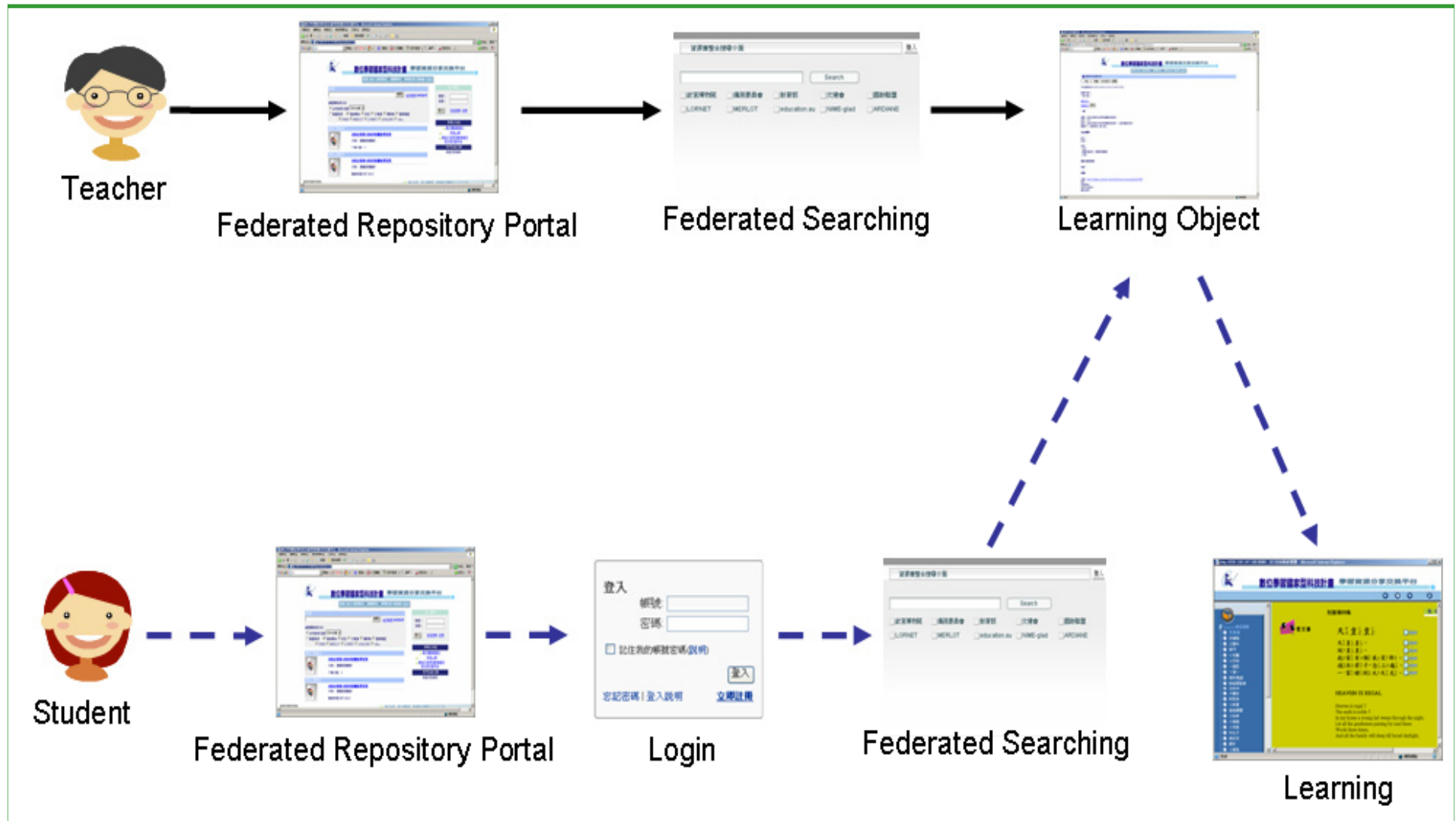



System architecture

Everyone can contribute + No quality control = Web 2.0 repository

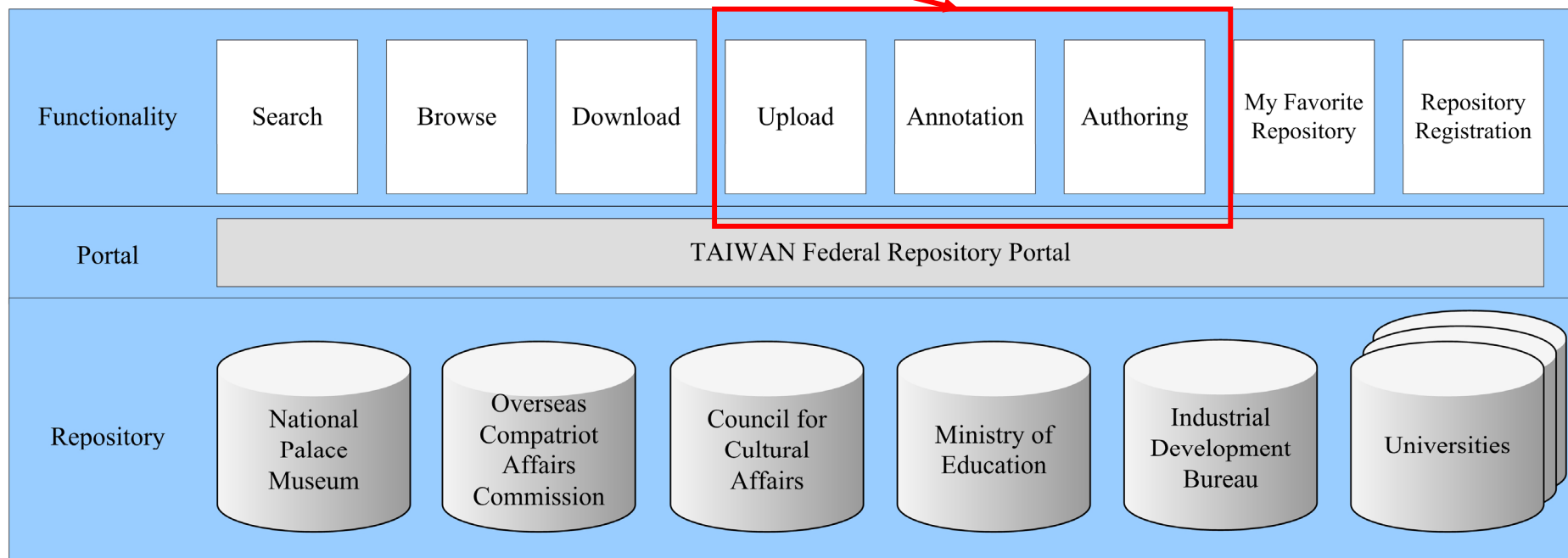



Upload

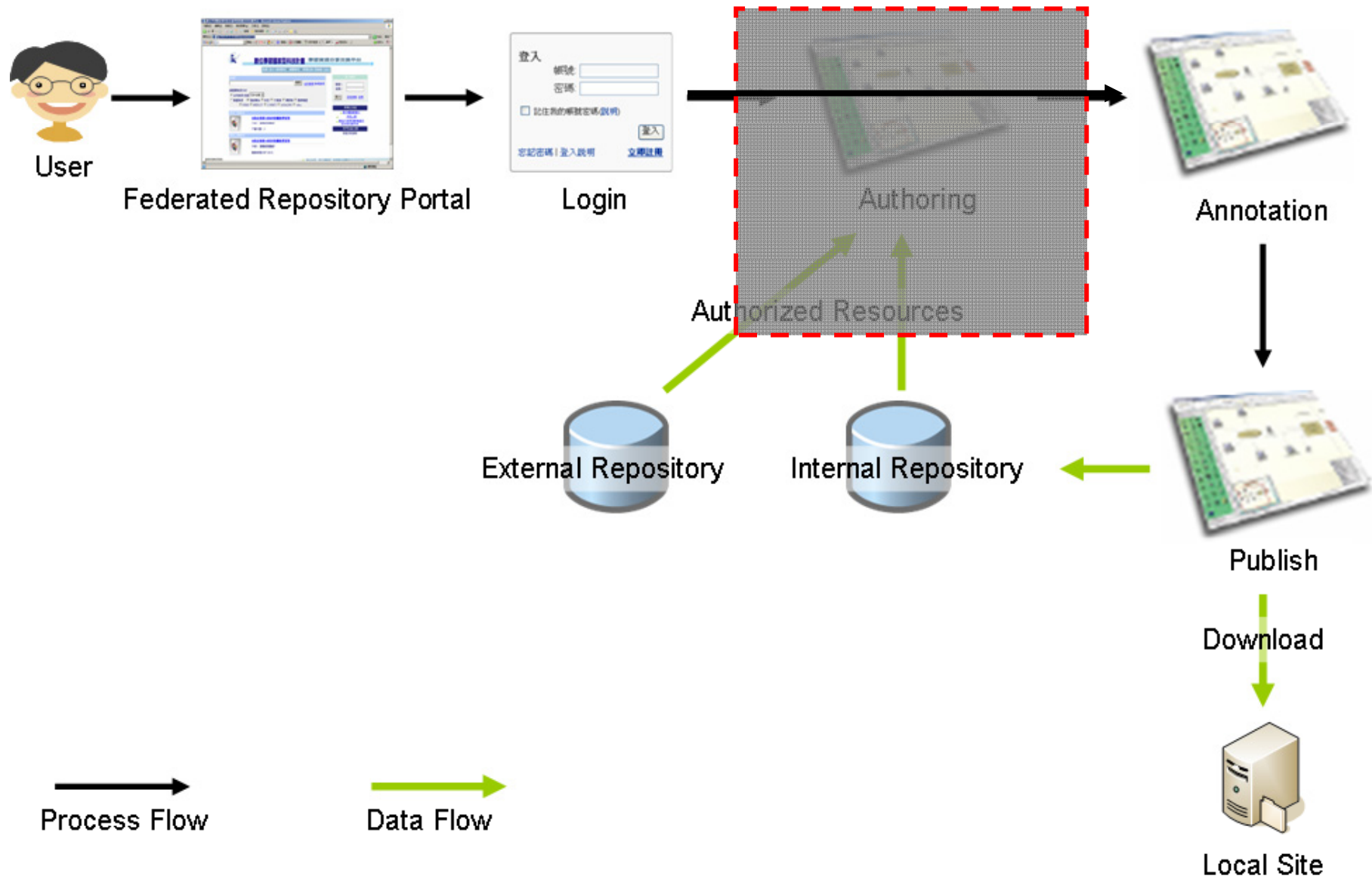



Authoring and Upload

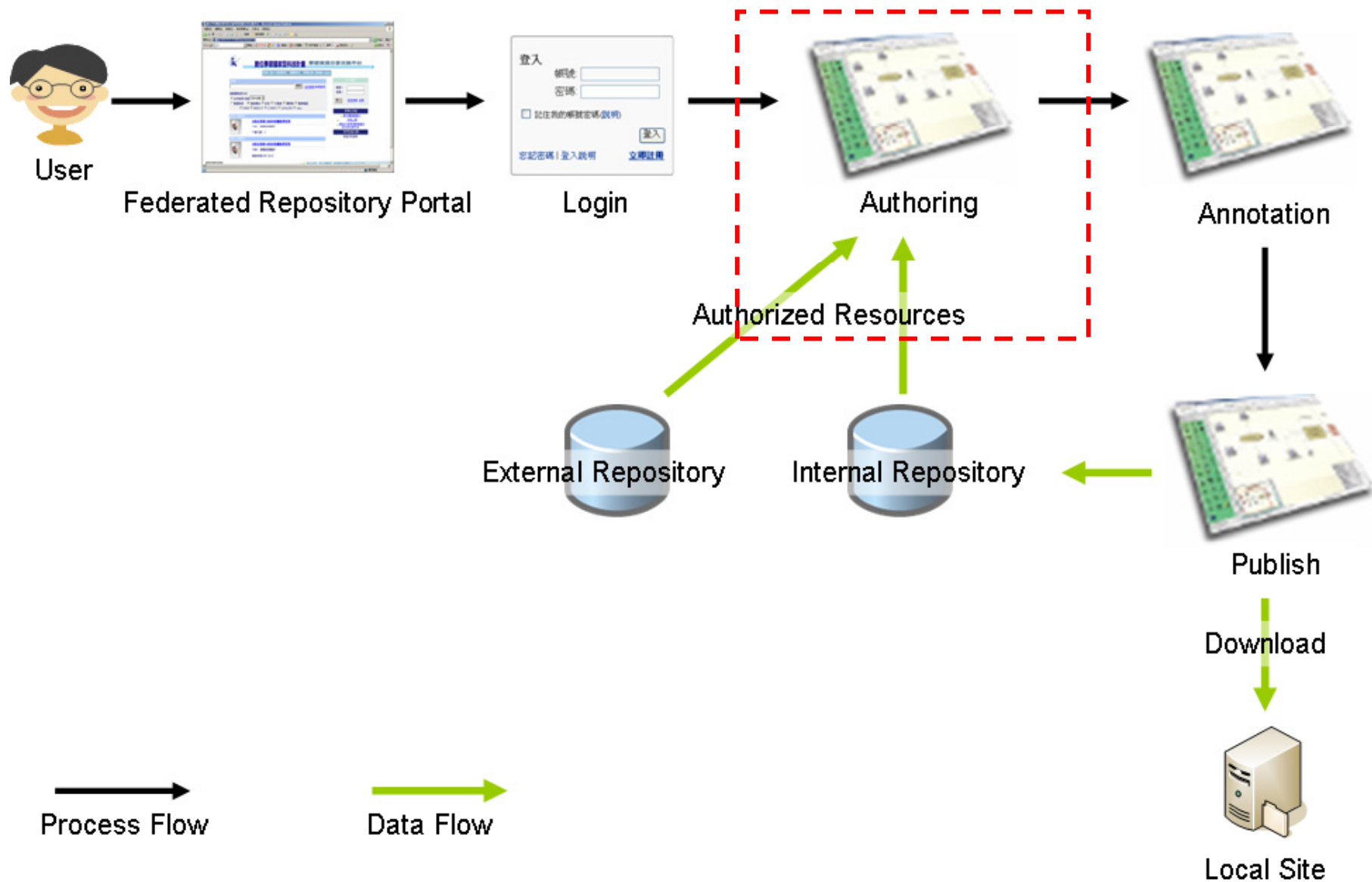



No Quality Control for new items

- No expert review
 - What is a “Good/Bad” content?
 - Useful/Useless one
 - Who should pay for?
 - Review for 1,000,000 learning object?
- Quality Certification only for people who need
 - Vendors
 - Institutes (organizations)



How to ensure the quality of Learning object

- We only need a mechanize
 - Ranking (scoring, book-marking)
 - Hit rate
 - Prosecution
- Let people make the decisions



Demonstration

<http://www.LORT.org.tw>



Future works

- New techniques (standards) implementation
 - Common Cartridge
 - Metadata generator (annotation agent)
 - Digital Right Management
- Find out a Best Practice in specific domain (Chinese Learning, science, IT ...)
 - Users' need
 - Vendors' need
 - standards
- Business plan



Thank you Q&A

李鎮宇
Chen-Yu Lee
leoli@iii.org.tw
Institute for Information Industry (III),
Taiwan, R.O.C.